

PRODUCT INFORMATION PACKET

Model No: 184TTFC6080
Catalog No: GT1108
2,1200,TEFC,184T,3/60/575
Totally Enclosed Fan Cooled (TEFC)



Regal and Marathon are trademarks of Regal Beloit Corporation or one of its affiliated companies.
©2018 Regal Beloit Corporation, All Rights Reserved. MC017097E



Nameplate Specifications

Output HP	2 Hp	Output KW	1.5 kW
Frequency	60 Hz	Voltage	575 V
Current	2.4 A	Speed	1182 rpm
Service Factor	1.15	Phase	3
Efficiency	88.5 %	Duty	Continuous
Insulation Class	F	Design Code	B
KVA Code	K	Frame	184T
Enclosure	Totally Enclosed Fan Cooled	Overload Protector	No
Ambient Temperature	40 °C	Drive End Bearing Size	6206
Opp Drive End Bearing Size	6205	UL	Recognized
CSA	Y	CE	Y
IP Code	43		

Technical Specifications

Electrical Type	Squirrel Cage Induction Run	Starting Method	Across The Line
Poles	6	Rotation	Reversible
Mounting	Rigid base	Motor Orientation	Horizontal
Drive End Bearing	Ball	Opp Drive End Bearing	Ball
Frame Material	Cast Iron	Shaft Type	T
Overall Length	14.8 in	Shaft Diameter	1.125 in
Shaft Extension	2.75 in	Assembly/Box Mounting	F1/F2 Capable
Outline Drawing	B-SS620290	Connection Diagram	A-EE7300

This is an uncontrolled document once printed or downloaded and is subject to change without notice. Date Created: 06/29/2018

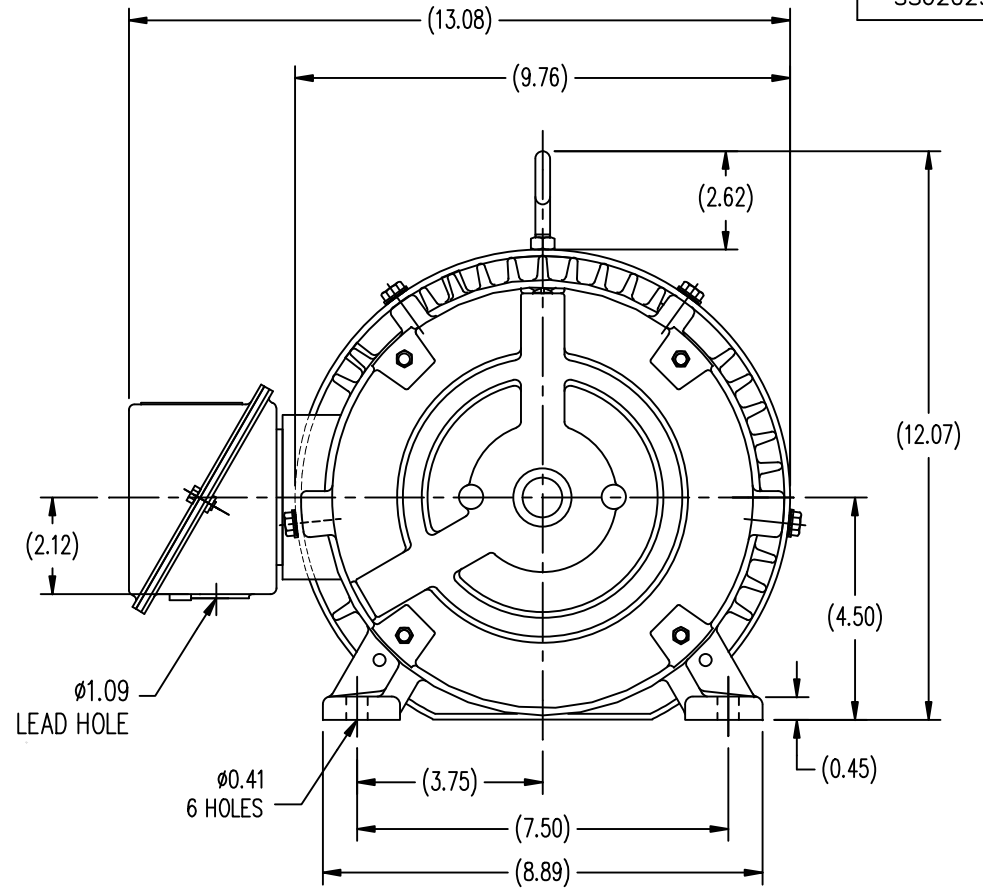
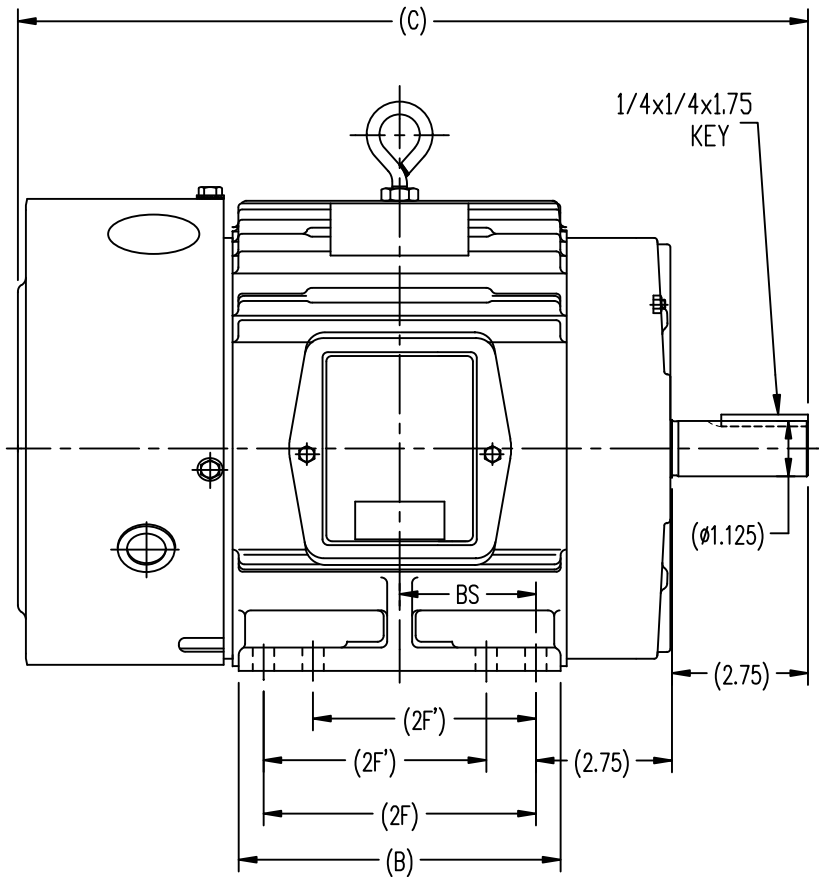

182T	14.80	5.50	4.50	/	2.25
184T	15.81	6.55	5.50	4.50	2.75
FRAME	C	B	2F	2F'	BS

NO.		REVISION	BY & DATE	CHK	ANG	±1/2-	FINISH	PREV			
THIS DRAWING IN DESIGN AND DETAIL IS OUR PROPERTY AND MUST NOT BE USED EXCEPT IN CONNECTION WITH OUR WORK. ALL RIGHTS OF DESIGN AND INVENTION ARE RESERVED. THIS IS AN ELECTRONICALLY GENERATED DOCUMENT - DO NOT SCALE THIS PRINT				RFP			CAD FILE	SS620290	SIZE	DRAWING NO.	REV.
				DIST					B	SS620290	

TOLERANCES UNLESS SPECIFIED		REGAL-BELOIT CORPORATION	DRAWN	HZJ 03-05-2010
DEC.	INCHES		CHK	ZYH 03-05-2010
.X	±.1		APPD	CL 03-05-2010
.XX	±.03		SCALE	1=2.5
.XXX	±.005		REF	
.XXXX	±.0005	MAT'L		
		TITLE	OUTLINE	
			182/184T FR TEFC-CAST IRON	

**THREE PHASE - SINGLE VOLTAGE
MOTOR - CONDUIT BOX @ 'A'**

**TO REVERSE ROTATION:
INTERCHANGE ANY TWO
LINE LEAD CONNECTIONS.**

TERMINAL BLOCK WHEN SPECIFIED



VIEW OF TERMINAL END

**IF MOTOR HAS
6 LEADS**



A-9806 DECAL

**OPTIONAL CORD
CONNECTION**



DRAWING REVISION AB	REVISION BY JJB	DATE 06-27-2017
ECO ECO-0125361	APPROVED BY TB	DATE 06-27-2017
ECO DESCRIPTION UPDATED TO CURRENT STANDARDS		
<small>COPYRIGHT REGAL BELOIT AMERICA, INC. ALL RIGHTS RESERVED. PROPRIETARY AND CONFIDENTIAL INFORMATION - THIS DOCUMENT IS THE PROPERTY OF REGAL BELOIT AMERICA, INC. ("OWNER") AND CONTAINS OWNER'S PROPRIETARY INFORMATION. ANY PERSON, CORPORATION OR OTHER FIRM RECEIVING IT IS DEEMED, BY RECEIVING IT, TO AGREE THAT IT, AND/OR ANY PART OF IT, SHALL NOT BE DISCLOSED TO ANY PERSON, CORPORATION OR OTHER ENTITY, DUPLICATED, AND/OR USED, EXCEPT AS EXPRESSLY APPROVED IN WRITING IN ADVANCE BY OWNER. THIS DOCUMENT SHALL BE RETURNED TO OWNER UPON REQUEST. IT MAY BE SUBJECT TO CERTAIN RESTRICTIONS UNDER APPLICABLE EXPORT CONTROL LAWS AND REGULATIONS.</small>		



DRAWN BY DA
DATE 03-26-1993
APPROVED BY TB
DATE 03-26-1993
REFERENCE
THIRD ANGLE PROJECTION

Regal Beloit America, Inc.		
		DESCRIPTION CONNECTION DIAGRAM EXTERNAL - SINGLE VOLTAGE - 3Ø MOTOR
MATERIAL	PROCESS/FINISH	
SIZE A	DRAWING NUMBER EE7300	SHEET 1 OF 1

